

High Quality  
Best Service  
Ball Valves  
Art

# DIXON Valves

IMFLUID Ltda.

Compañía N° 1973, Santiago, Chile

Central (fax) : 56-02-6967479

## MODEL: BODX 3PT

3-PC SS 316 BALL VALVES, FULL PORT,

W/SOLID BALL, THREAD NPT ENDS

150 PSI (STEAM), 1000 PSI (WOG), W/ISO 5211 MOUNTING PAD,  
SEAT REINFORCED TEFLON PTFE, OPTION: LOCKING DEVICE  
VENTED BALL.



### Dimensions List:

SIZE	d	L	H	H1	H2	D	J	K	ISO	M
1/4	11.6	60	52	22.7	15	108	5/16-24	5	F03	M5
3/8	12.7	60	52	22.7	15	108	5-16-24	5	F03	M5
1/2	15	75	57	27.2	17.5	108	M8x1.25	5	F03	M5
3/4	20	77	59	31	17	132	3/8-24	6.5	F03	M5
1	25	85	71	37	21.5	153	7/16-14	8	F04	M5
1-1/4	32	104	78	42.1	21	153	7/16-14	8	F04	M5
1-1/2	38	120	91	49.5	27.1	195	M12x1.75	8.5	F05	M6
2	50	130	92	56	27.1	195	M12x1.75	8.5	F05	M6
2-1/2	63.5	165	131	75	40.2	265	3/4-10	12	F07	M8
3	76	182	140	82.8	39.2	265	3/4-10	12	F07	M8
4	97	230	175	118.3	46	285	1"-8 UNC	16	F10	M10

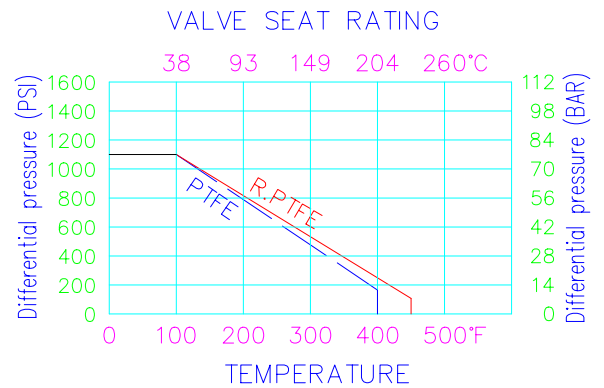

### Materials Specification:

NO	PART NAME	MATERIAL
1	BODY	ASTM A351 CF8M/CF8
2	END CAP	ASTM A351 CF8M/CF8
3	SOLID BALL	ASTM A351 CF8M/CF8
4	BALL SEAT	PTFE
5	BODY SEAT	PTFE
6	THRUST WASHER	PTFE
7	STEM PACKING	PTFE
8	GLAND NUT	STAINLESS STEEL 304
9	WASHER	STAINLESS STEEL 304
10	HANDLE NUT	STAINLESS STEEL 304
11	STEM	STAINLESS STEEL 316
12	BOLT WASHER	STAINLESS STEEL 304
13	NUT	STAINLESS STEEL 304
14	BOLT	STAINLESS STEEL 304
16	GRIP	VINYL
17	STOP PIN	STAINLESS STEEL 304

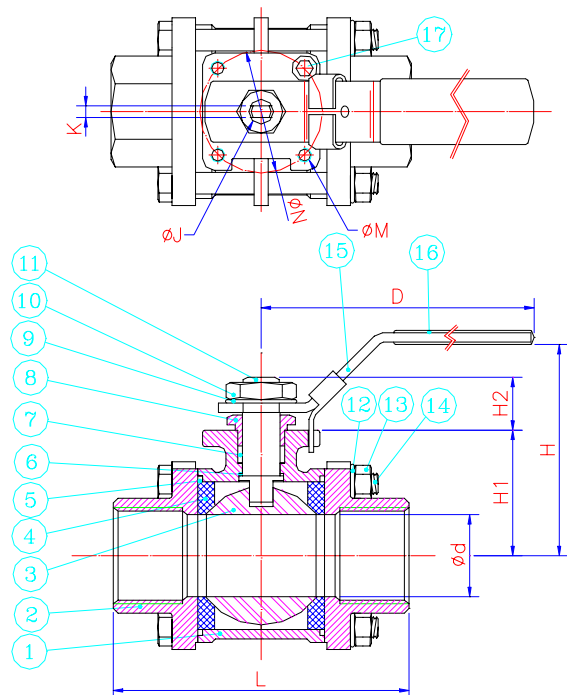

We hereby reserve the rights of any alternative dimension that we could help to improve our valve's quality and working efficiency