



DIXON Valves

IMFLUID Ltda.

Compañía N° 1973, Santiago, Chile

Central (fax) : 56-02-6967479

MODEL NO : DX2PT

2-PC SS316 BALL VALVE, FULL PORT , 1000WOG

*INVESTMENT CASTING BODY

*BLOW-OUT PROOF STEM DESIGN

*WORKING PRESSURE : 1000 PSI WOG

*END CONNECTION : NPT

*OPTIONAL : LOCKING DEVICE,
TAPPED & DRILLED PAD

*TEST PRESSURE

SEAT (AIR): 80PSI

SHELL (HYDROSTATIC): 1500PSI



Dimension List :

Size	A	C	D	E	W1	W2	F	G	W(kg)
1/4"	11.6	55	46	108	12.7	28.5	22	28.5	0.29
3/8"	12.7	55	46	108	12.7	28.5	22	28.5	0.24
1/2"	15	65	56	108	12.7	28.5	26	34	0.35
3/4"	20	74	62	132	22.4	35	32.5	40.5	0.54
1"	25	88	70	160	22.4	35	40	48	0.88
1-1/4"	32	102	78	160	25.4	38.1	49	59.5	1.32
1-1/2"	38	110	92	195	25.4	38.1	55	70	1.9
2"	50	125	102	195	25.4	38.1	69	86.5	2.98
2-1/2"	65	162	140	270	35	58	85.5	112.5	6.2
3"	80	178	148	270	35	58	101.5	135	9
4"	100	280	175	295	50	62	132	171	18.5

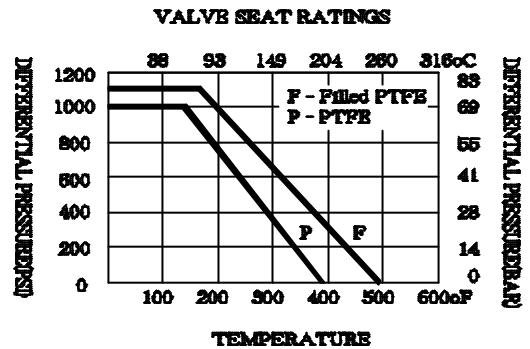

Materials Specification :

1	BODY	ASTM A351 GR. CF8M
2	SOLID BALL	ASTM A 351 GR. CF8M
3	BALL SEAT	PTFE
4	BODY SEAL	PTFE
5	END CAP	ASTM A351 GR. CF8M
6	STEM	SS316
7	THRUST WASHER	PTFE
8	STEM PACKING	PTFE
9	HANDLE	SS 304
10	GLAND NUT	SS 304
11	STEM WASHER	SS 304
12	HANDLE NUT	SS 304
13	GRIP	VINYL
14	LOCKING DEVICE	SS 304

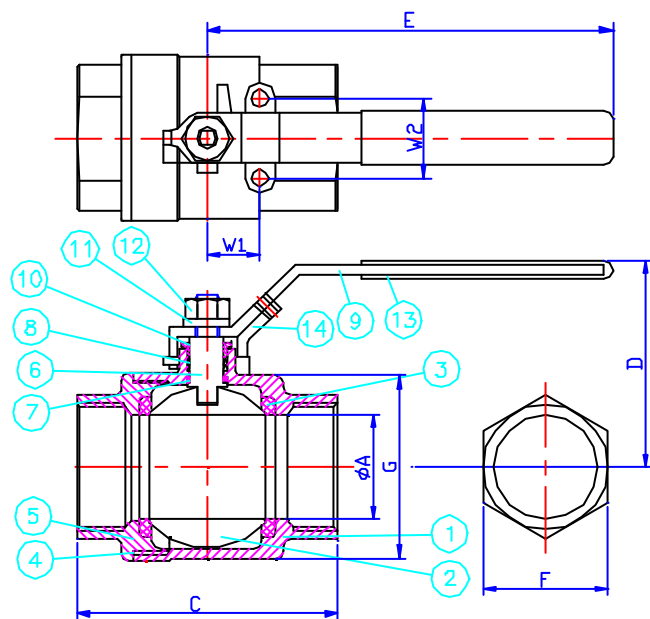

We hereby reserve the rights of any alternative dimension that would help to improve our valve's quality and working efficiency